

# 上海百图低温阀门有限公司

——专业制造与研发低温阀门

## BAITU Valve Introduction



## Company Profile

Located in the international metropolis--Shanghai, SHANGHAI BAITU CRYOGENIC VALVE CO., LTD. of which the registered capital is 10 million Yuan, is a private high-tech company specialized in designing, manufacturing, sales and related technical services of cryogenic valves.

At the moment of its establishment, the company has set the goal to develop new market by technological innovation, take the lead by its product technology and advanced process, and earn customers' satisfaction through the pursuit of high-quality and comprehensive services. In the future, the company will achieve a bigger and stronger scale. At present, Our company has achieved the Manufacture License of Special Equipment for cryogenic valves issued by the General Administration of Quality Supervision of China and 51 patents in valve series for cryogenic insulation gas cylinders.

The main products include cryogenic valves for LNG storage and transportation equipment, valve series for air separation, cryogenic insulated cylinders, and hydrogen application etc. The maximum nominal diameter is 150mm while the maximum working pressure is 35 MPa, and the lowest operation temperature is -253°C. In order to ensure the stability and security of valves, our company has equipped with advanced manufacturing equipment, testing facilities and mature testing means.

"Quality, credit, and brand" is our business objective, "performing real work, stressing practical results, honoring sincere cooperation and realizing mutual development" is our code of conduct, and achieving win-win by establishing long-term and stable strategic cooperative partnership with our customer is the consistent pursuit of our company.

# Cryogenic Valve Solutions Worth Your Trust

**150** maximum nominal diameter  
**mm**

**35** maximum working pressure  
**MPa**

**-253** lowest operation temperature  
**°C**



## Production Equipment

Quality is a magic weapon for the existence. The present brand image of BAITU company comes from consistent quality concentration.

The company has established a job responsibility system for quality control involving everyone from the general manager to each staff member. Centering upon the quality, quality control targets are set for all levels and a quality control organizational system is also formed.



The pursuit of the quality by BAITU people is fully embodied in the whole process ranging from the evaluation on the supplier, the acceptance of the purchased products, the concentration on the control of manufacturing process, and delivery & services, to the internal quality checking, the strict testing on the product, the control of off-grade products, etc.





## Research & Development Team



## Excellent Team to Achieve Win-win Cooperation

Customer service representatives work directly with the production personnel to follow up PO and to ensure on-time shipment.

Ranging from professional salesmen who contact directly with customers, to the skilled technical workers who manufacture products.

All levels of BAITU make a commitment to high quality and satisfy our customers to the greatest extent.





## Quality Control

- 1. In accordance with the domestic and international relevant product standards for designing and manufacturing;
- 2. Product manufacturing quality control strictly in accordance with the requirements of laws and regulations, established a perfect quality assurance system;



## Quality Control during Manufacturing Processes

- 3. For each valve and strict factory inspection, to ensure that the factory 100% qualified rate.





# Advanced Inspection



The quality of our products originates from the passion of all staffs' to the work, the scientific management of the processes and the observance of the tenet of "centering on customers".

Meanwhile, we shall further consider "honesty" the footstone for enterprise's future development.



# Quality based on Advanced Inspection

Improvement of quality promotes the development of the brand, and the good credit standing formed over the years leads to BAITU's increased popularity in customers.





# Qualifications & Certificates



Honor is the best summary of the past, and is also the best encouragement for the future. In the pursuit of 'selfdevelopment, repaying society, serving society'; BAITU has made splendid achievements. Honor belongs to the past and strength will rewrite the future.

Like sports competition, market competition shows no sympathy to the weak, and flowers and medals go always to the strong. BAITU people will not get conceited because of victory or disheartened in case of defeat.

They will constantly keep their natural vitality and transmit the enterprise impetus and cohesion, which contributes greatly to the brilliant achievements made by BAITU.



## Exact Technics Authoritative Verification

In the process of future business, BAITU will continue to march forward courageously and rely on its solid basis to create limitless development space by means of sincerity, innovation and sweat.



# 公司介绍 Company Introduction



## 公司发展重大事件 Company History

公司于2010年正式成立  
Established in 2010



公司于2017年6月在张  
家港成立分公司——张  
家港百图阀门有限公司  
Subsidiary Company  
in Zhangjiagang in  
June, 2017

# 公司介绍 Company Introduction

## Factory Area

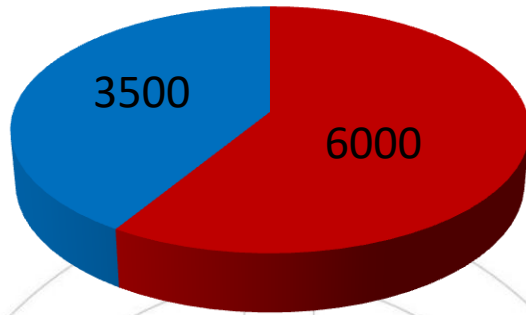

unit: m<sup>2</sup>

- SHANGHAI BAITU
- SUBSIDIARY

	Engineers & Technicians	10
	Quality Control	10
	Production Team	118
	Marketing Team	13
	Management etc.	19

**Total : 170**



21 patents

2 high-tech achievements



2 computer software copyrights

1 cooperation with University of Shanghai for Science and Technology



1 cooperation with Shanghai Tongji University

# Sales Achievement

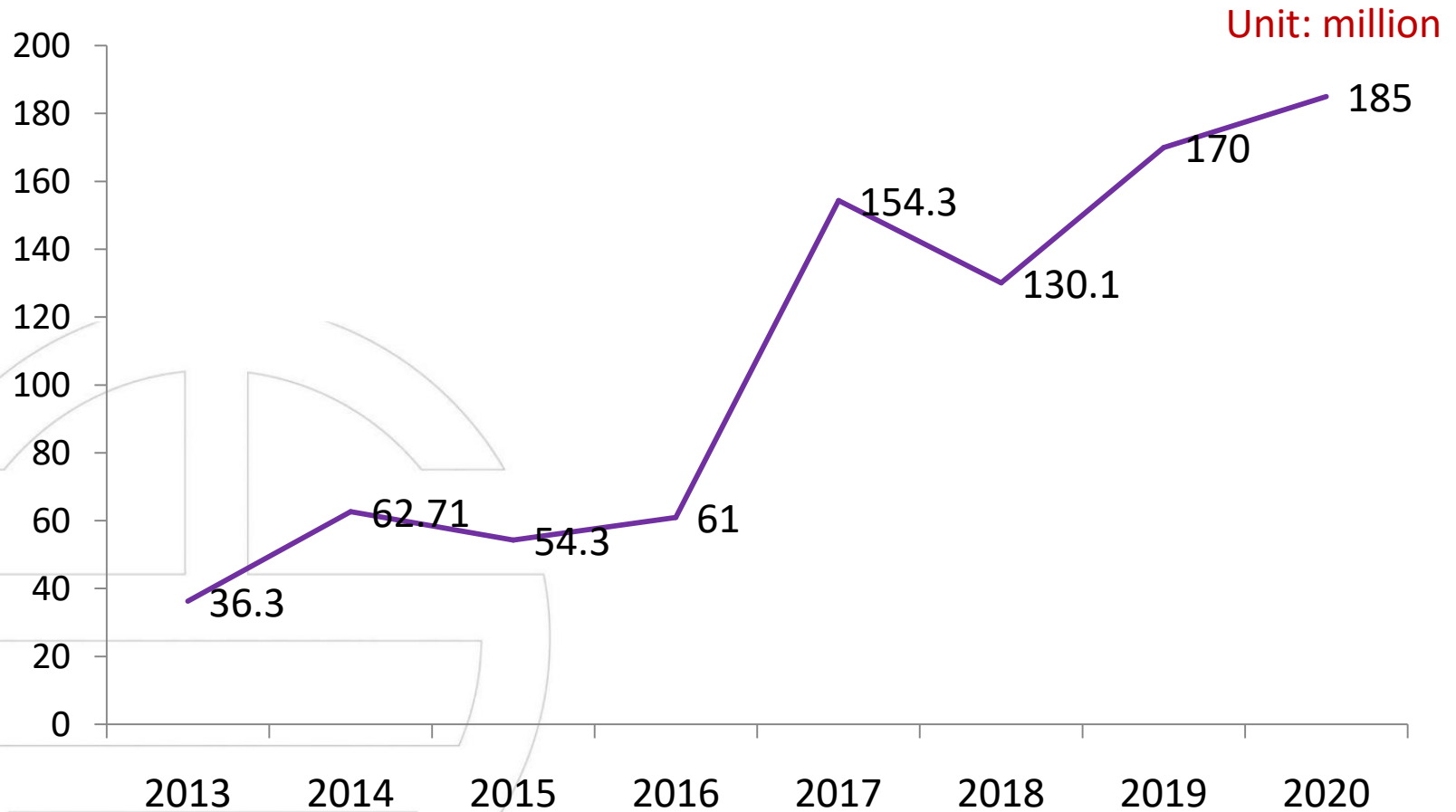

# 企业资质 Qualification



BAITU CRYOGENIC VALVE

## International Certification



ISO 9001

ISO/TS16949

ECE R110

CE

EAC

# 产品介绍 Product Information

Hydrogen Valve

Cylinder Valve

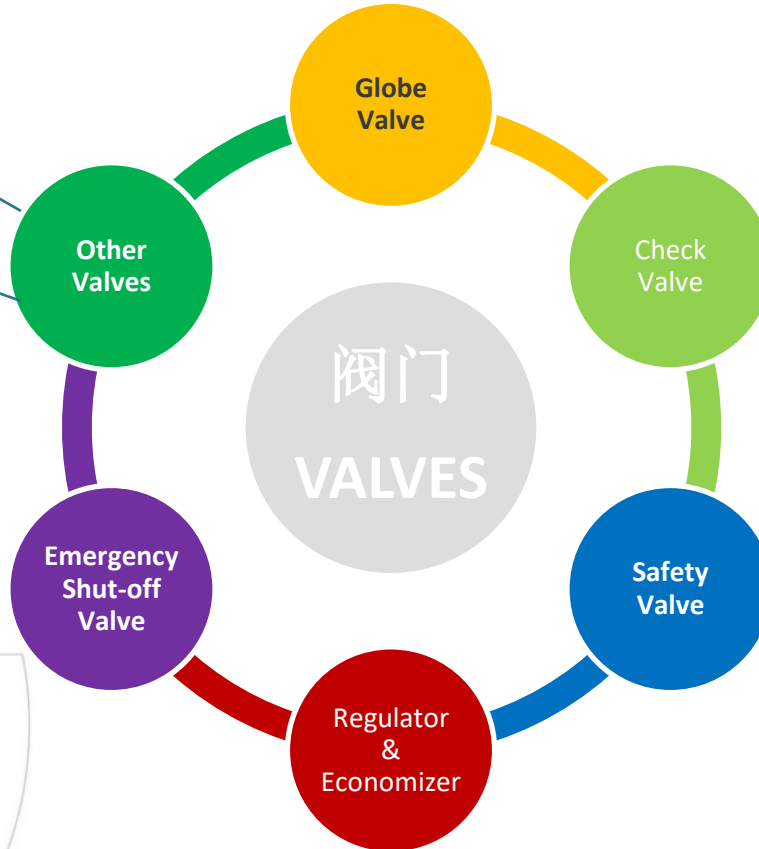

**BAITU**

**CRYOGENIC VALVES**

## 低温截止阀 Cryogenic Globe Valve



## 低温安全阀 Cryogenic Relief Valve



## 低温止回阀 Cryogenic Check Valve



## 其它低温阀门 Other Cryogenic Valves



旋卡座  
Charging Device

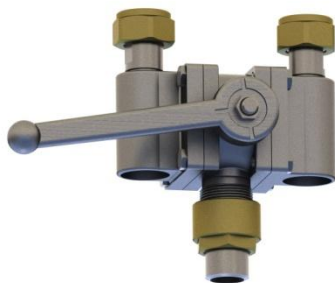

三通球阀  
Diverter Valve



阻火器  
Flame Arrester



真空阀  
Vacuum Jacketed Valve



组合充灌阀  
Fill Valve Assembly



羊角（快速接头）  
Quick Joint

# 产品介绍 Product Information

## 低温调压阀 Regulator & Economizer



Breakaway Coupling



Air-actuated Emergency Shut-off Valve



# 产品介绍 Product Information

## 气瓶用低温阀门 Valves for Cryogenic Cylinders



拉断阀  
Breakaway Coupling



止回阀  
Check Valve

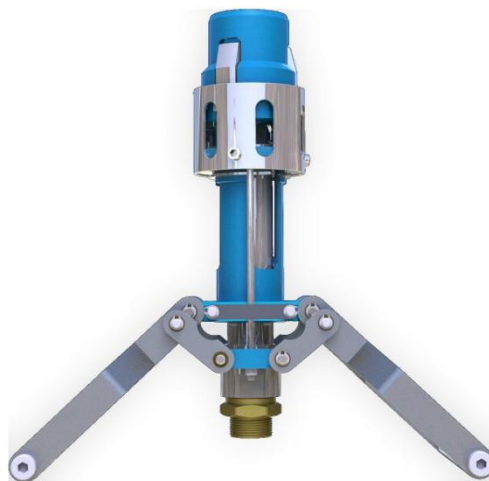

LNG充装接头  
LNG Coupling

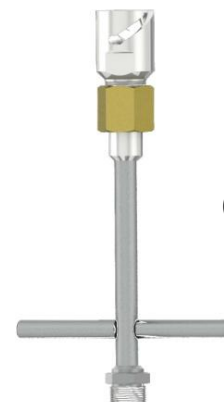

回气接头  
Coupling for  
Backing Gas



加气口  
Refueling  
Receptacle

# 应用案例 Application



Filling station & Skid Equipment

# 应用案例 Application

## Cryogenic Tank



## Cryogenic trailer & Container

# 应用案例 Application

## 低温绝热气瓶 Cryogenic Cylinders



# 应用案例 Application

## LNG液化工厂 LNG Liquefied Plant



# 应用案例 Application

## LNG船用供气系统 LNG Ship Application



# 应用案例 Application

## 车载氢能应用 Hydrogen Vehicle Cylinder

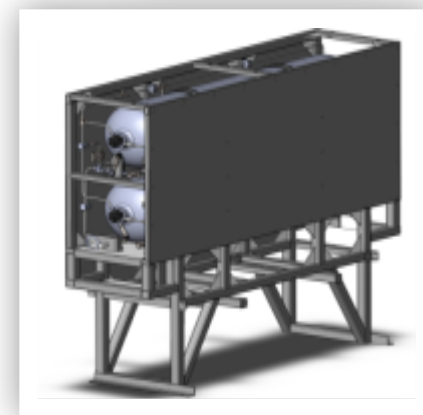
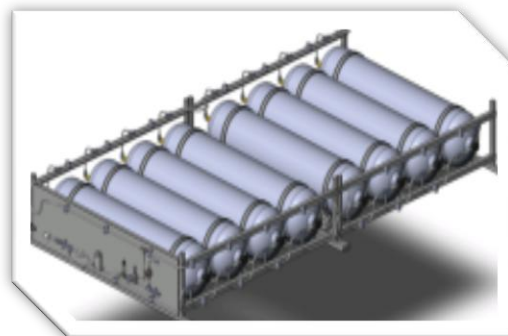



# International Business

## International Customers List

Singapore—Air Products Singapore Industrial Gases

Thailand—Cryotech Asia Co., Ltd.

Thailand—IBC Industrial Co., Ltd.

Thailand—UNI Enterprise Co., Ltd.

Spain—Indox Energy Systems, S.L.

Turkey—Habas Group

Turkey—TEKNOSER

Indonesia—PT. HEISZCO ATARASINDO

Brazil—EGSA EQUIPAMENTOS PARA GAS DO BRASIL LTDA

Russia—Cryobak LLC

Russia—SISTEMY PODACHI TEHNICHESKIH GAZOV LTD



# 客户业绩 End Users



**SINOMA**  
中材科技



**rein** 蓝能



**EFO**<sup>®</sup>  
上海伊丰



**CIMC ENRIG**  
中集安瑞科

**SOER**  
山东索尔科技

**Jerrell**  
杰瑞集团



**明欣**



**CHART**  
CHINA



期待您的加入  
Welcome to join

# 客户业绩 End Users



中船圣汇装备有限公司  
CSSC SHENGHUI EQUIPMENT CO.,LTD.



**Thank you for your attention!**

 百图低温阀门  
BAITU CRYOGENIC VALVE

BUILD ON LOGGING MIND



**24H Hotline: 400-9215-698**